

(No Model.)

C. M. DAVIS.  
TURNING MACHINE.

No. 514,216.

Patented Feb. 6, 1894.

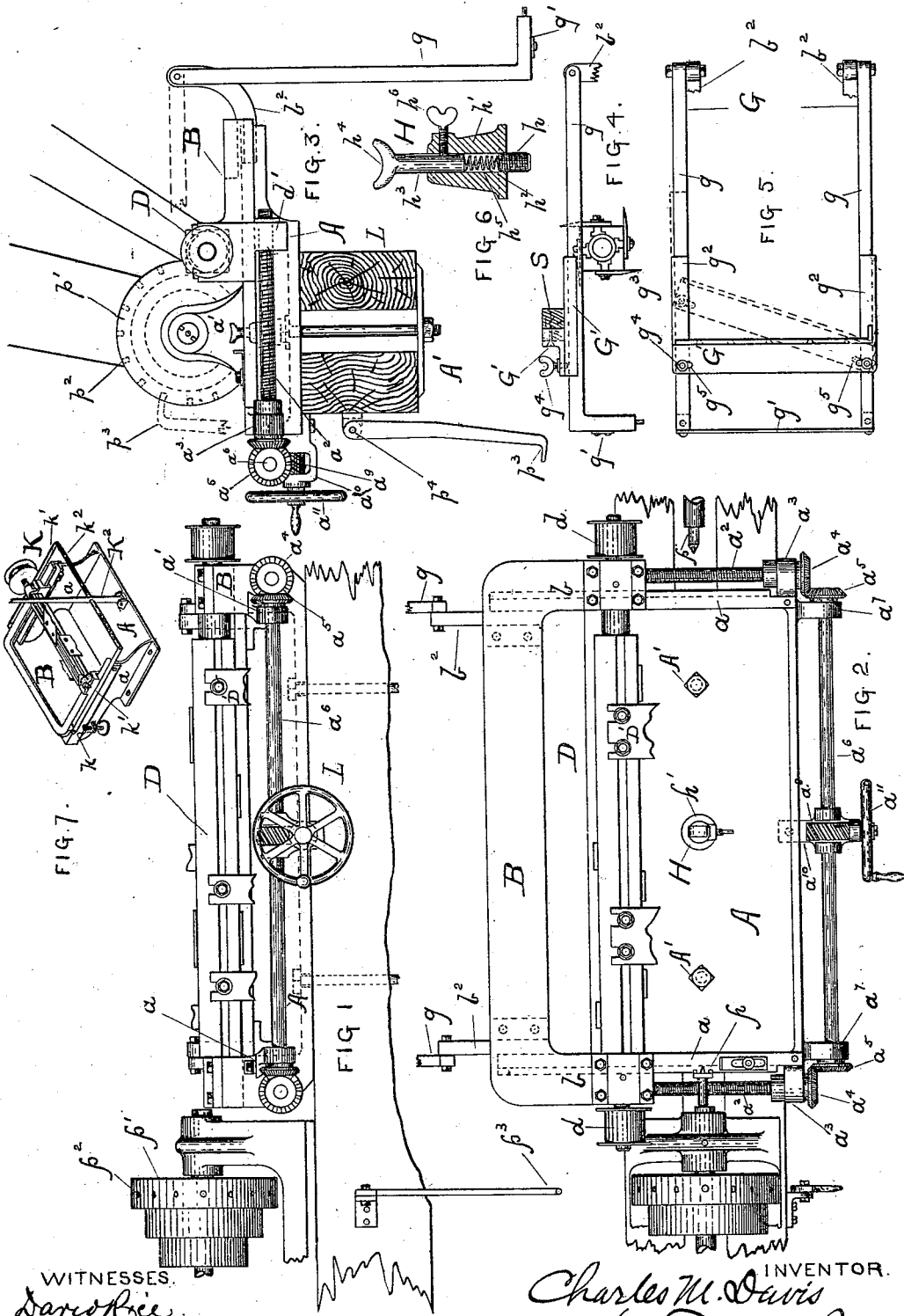

WITNESSES.  
*Daniel Bee*  
*Charles L. Leland*

INVENTOR.  
*Charles M. Davis*  
by *Edward S. Beach*  
ATTY

# UNITED STATES PATENT OFFICE.

CHARLES M. DAVIS, OF BOSTON, MASSACHUSETTS, ASSIGNOR OF ONE-HALF  
TO ASHER A. WHITE, OF SAME PLACE.

## TURNING-MACHINE.

SPECIFICATION forming part of Letters Patent No. 514,216, dated February 6, 1894.

Application filed September 30, 1893. Serial No. 486,890. (No model.)

*To all whom it may concern:*

Be it known that I, CHARLES M. DAVIS, of Boston, in the county of Suffolk and State of Massachusetts, have invented a new and useful Improvement in Turning-Machines, of which the following is a specification, reference being had to the accompanying drawings, in which—

Figure 1 is a front elevation of a portion of an ordinary lathe provided with my new attachment. Fig. 2 is a top plan of what is shown in Fig. 1. Fig. 3 is an end elevation of what is shown in Figs. 1 and 2. Fig. 4 is an end elevation of an auxiliary frame with a sliding work support upon it. Fig. 5 is a top plan view of what is shown in Fig. 4. Fig. 6 is a sectional view of a work rest adapted for use upon the base plate of my new attachment. Fig. 7 shows a modification.

The object of my invention is to produce an improved turning machine for use in connection with ordinary lathes, and my invention relates to the art of turning irregular forms, especially in wood.

The first feature of my invention is an attachment for lathes, which attachment is wholly new with me, and is made up of a base plate having angular arms or uprights, which are formed at their upper or outer ends with tracks, upon which is mounted a reciprocating cutter-carrier, which supports a rotary cutter journaled therein; the reciprocating cutter-carrier being connected with the base plate by any suitable mechanism for moving the cutter-carrier from and toward the operator. This is the broadest feature of my invention, and by its embodiment I am enabled to produce an attachment for ordinary lathes, the puppets of which are at each end of my attachment when the same is in place on the lathe for use. It will be seen that when my attachment is removed from the lathe, the lathe is wholly unincumbered between the puppets, and in condition for other uses, the cutter and all its connected parts being then removed together and at once.

Other important features of my invention are hereinafter pointed out.

In the drawings, showing the best embodiment of my invention now known to me, A

is the base plate, and  $a a'$  the angular arms, or uprights, the tops of which form ways, upon which the reciprocating cutter-carrier B moves. A rotary cutter-head D is journaled into the arms  $b b$  of the cutter-carrier B, and provided with pulleys  $d$  for the rotation of the cutter-head, as will be readily understood to all skilled in the art without further description. Cutter-carrier B is formed with projections  $d'$  at either end, which are engaged by screws  $a^2 a^2$  mounted in lugs  $a^3$  of frame A  $a a'$ . These screws are each provided with a beveled gear  $a^4$ , which mesh with beveled gears  $a^5$  on the shaft  $a^6$ , which is at right angles to the screws  $a^2 a^2$ , and is mounted in lugs  $a^7 a^7$ , carried by the frame A  $a a'$ . Shaft  $a^6$  carries a gear  $a^8$ , which meshes with a screw  $a^9$  mounted in bracket  $a^{10}$  fast to the frame A  $a a'$ , the screw being provided with a hand-wheel  $a^{11}$ . Rotation of shaft  $a^6$  drives the screws  $a^2$  simultaneously, and cutter-carrier B is thereby caused to travel upon its ways either backward or forward, according to the direction in which the shaft  $a^6$  is rotated.

Base-plate A is formed in such wise as to enable it to be firmly clamped upon the bed-plate L of the lathe between the puppets  $p$  thereof, the work being secured between the puppets and between the front of the machine and the cutter head D, so that the cutter-head may be reciprocated against and out of contact with the work by means of the carrier operating mechanism already described, or the equivalent thereof.

Inasmuch as the mechanical means which I employ to reciprocate the cutter-carrier are supported by the frame A  $a a'$ , I am enabled to produce an attachment which may be readily mounted upon and removed from any ordinary lathe; and an important feature of my invention is to support the cutter-carrier's reciprocating mechanism (whatever may be the form of that mechanism), upon the frame of my attachment—that is, upon the attachment itself and not upon any independent part. The base-plate A is preferably bored to receive the clamps A', whereby it is secured to the bed of the lathe. The blades D' have cutting edges of any desired configura-

tion, and consequently a great variety of irregular forms may be turned on my attachment.

If it is desired to turn out work which is polygonal in cross section, I lock the live-head-stock, disk  $p'$  of which is provided with holes  $p^2$  on its periphery to receive the hook  $p^3$  hinged at  $p^4$  to the lathe; and ship belt from the live-head-stock. Thereupon the work is held stationary and the cutter advanced to operate on the desired portion of the work. A surface being cut, the cutter-head is moved away from the work, hook  $p^3$  drawn from its hole  $p^2$  in the disk  $p'$ ; and the disk  $p'$ , which is fast on the journal of puppet  $p$  in the live-head-stock, rotated so as to shift the work the desired distance, when the disk is again locked and the work again subjected to the action of the cutters.

The holes in the periphery of the disk  $p'$ , together with the hook  $p^3$  are a convenient form of lock for the live-head-stock, but of course other forms of lock may be employed. The holes  $p^2$  in disk  $p'$  have a definite relation one to the other, and bear a definite relation to the number of sides of the polygonal form produced by rotating the disk. That is, if the disk be provided with sixteen holes  $p^2$ , and the disk be shifted from hole to hole, sixteen sided work will be produced. If it have sixteen holes, and be rotated so as to skip every other hole, then octagonal work will be produced. This illustrates the principle of this feature, and the utility of a graduated indicating disk  $p'$  combined with means for locking it in any desired position.

Another feature of my invention consists in the auxiliary frame G, which is made up of side pieces  $g$   $g$ , and cross piece  $g'$ . Frame G is hinged to main frame A  $a$   $a'$  in this case upon arms  $b^2$  thereof. Frame G is thus readily swung out of the way when it is not in use, and when the workman desires to use it, it is readily swung into place, as will be plain from Fig. 3, where it is shown by dotted lines in its operative position.

When frame G is used, it is swung into position shown by dotted lines in Fig. 3, and the stock S (see Fig. 4) placed in front of the reciprocating work-carrier  $G'$ , which slides upon the side pieces  $g$  of frame G. It will be seen from Fig. 4 that when the stock S is in place on the work-carrier  $G'$ , the cutter-head D will operate upon the lower portion of the stock, whose under side will consequently be cut according to the configuration of the cutting edges of the blades. If it should be desired to cut stock S diagonally, the work-carrier  $G'$  is shifted at one or the other of its ends, so as to be diagonal to the side pieces  $g$ ; and to readily accomplish this, the track pieces  $g^2$ , which are between the side pieces  $g$  and the work-carrier  $G'$ , are provided with holes  $g^3$  to receive the screws  $g^4$ , which pass through slots  $g^5$  in the work-carrier  $G'$ , whereby work-carrier  $G'$  may be adjusted diagonally in relation to the side pieces  $g$ , which are of course

at right angles to the longitudinal axis of the cutter-head D.

In many cases it is desirable to provide base-plate A with an automatically adjustable work-support, so that as one side of a stock is cut away when the stock is supported between the puppets  $p$   $p$ , the support automatically moves upwardly to keep in proper contact with the work. Ordinarily this work-support is midway between the ends of frame A  $a$   $a'$  and in line with the puppets of the lathe upon which the attachment is used. I therefore, form base-plate A with a hole near the middle of its upper surface, to receive the shank  $h$  of the automatically adjustable work-support H. This support consists of a block  $h'$ , having a chamber  $h^2$ , and provided at its lower end with a shank  $h$ , by which it is mounted upright on the upper surface of the base-plate A, as shown in Figs. 2 and 3. Chamber  $h^2$  receives the shanks  $h^3$  of a rest  $h^4$ , and between the bottom of the chamber and the inner end of shank  $h^3$  a spring  $h^5$  is interposed. When the support H is to be used, it is set upright on base-plate A, and the rest  $h^4$  forced down against the tension of the spring  $h^5$  and clamped into position by clamp screw  $h^6$  through block  $h'$  and engaging the shank  $h^3$ . The work being secured between the puppets, set screw  $h^6$  is turned back to release the shank, and the spring  $h^5$  forces the rest  $h^4$  of the work-support H against the work, and as the work is cut away, the continued expansion of the spring automatically keeps the work-support H in contact with the work, as will be readily understood by all skilled in the art without further description.

In Fig. 7 I show a modification, in which the mechanism for reciprocating the cutter-carrier B is made up of a swinging frame K and journaled at  $k$  to the cutter-carrier. This frame is composed of side pieces  $k'$ , a cross-piece  $k^2$ , which is connected with a hand-lever  $K^2$  journaled to the frame A  $a$   $a'$ . This mechanism is desirable for many classes of work, especially where the stock has knots, and the cutters require to be instantly moved away from the work. The operator using the hand-lever, more quickly discovers irregularities in the hardness of the stock operated upon, than does the operator who uses gear and screw mechanism for reciprocating the cutter-carrier, as hereinbefore described. In this modification also the mechanism for reciprocating the cutter-carrier is wholly supported and carried by the frame A  $a$   $a'$ , so that my attachment in this form, as well as in its other form hereinbefore described, may be removed bodily from the lathe, which is then accessible for other uses.

What I claim as my invention is—

1. In a lathe attachment, the herein described combination of a frame formed solely of a base and projecting arms which are formed with tracks and independent of and removable from the lathe frame and puppets; a re-

5 reciprocating cutter-carrier mounted on said tracks; a rotary cutter journaled in the reciprocating cutter-carrier; and means substantially such as described for actuating the cutter-carrier, said actuating mechanism being supported by said frame, all substantially as and for the purpose set forth.

10 2. In a lathe attachment, the combination of a frame formed of a base and projecting arms which are formed with tracks; a reciprocating cutter-carrier mounted on said tracks; a rotary cutter journaled in the reciprocating cutter-carrier; means substantially such as described for actuating the cutter-carrier, said actuating mechanism being supported by said frame; an auxiliary frame supported by the aforesaid frame and a work support moving on said auxiliary frame, all substantially as and for the purpose set forth.

3. In a lathe attachment, the herein described combination of a frame formed solely of a base and projecting arms, which are formed with tracks and independent of and removable from the lathe frame and puppets; a reciprocating cutter-carrier mounted on said tracks; a rotary cutter journaled in the reciprocating cutter-carrier; and means substantially such as described for actuating the cutter-carrier, said actuating mechanism being supported by said frame; an automatically adjustable work support mounted on said base between the projecting arms thereof, all substantially as and for the purpose set forth.

CHARLES M. DAVIS.

Witnesses:

CHARLES P. SEARLE,  
EDWARD S. BEACH.